

# Perspectives on Central European Cable Yarding Systems

Hans R. Heinimann<sup>1</sup>, Karl Stampfer<sup>2</sup>, Johannes Loschek<sup>3</sup>, and Leo Caminada<sup>4</sup>

**ABSTRACT** - Cable Yarding Technology has a long tradition in the Central European Alps. Outside Europe, sledge yarder technology became well known during the 1960's while the first European tower yarders were introduced during the 1970s. Although there has been much effort to improve yarding technology, only little is known about it outside Europe. The paper aims to present the state-of-the-art of both, yarder technology and technical production systems, and to identify future challenges. The introduction of fluid power was an important step to build compact yarders with a beneficial weight-performance relationship. Processor Tower Yarders PTY represent the state of technology; they integrate the drums, a steel spar, power supply, a boom, and a processor head on one carrier. An automatic control device for carriage movement and stop, together with radio-control made it possible to operate a yarding system with a crew of only two persons. In thinning operations, mechanization of tree processing results in cost savings of about 40% for both, the CTL-system with a steep slope harvester, and the FT-system with a processor tower yarder. Future improvements will focus on the reliability of system components, the optimization of harvesting system design and work force development by using simulators for training.

## 1 Introduction

Cable-based yarding technology has had a long tradition in Central Europe, the Pacific Northwest Region of the United States and Canada, and Japan. During the 1960s, European sledge yarder technology became well known, and in the 1970s, mobile tower yarders began to replace them. The introduction of fluid power technology in the 1970s, the use of automatic carriage control since the mid-1980s, and the integration of materials handling and processing functions into yarding machines were important steps of improvement. Outside Europe, only little is known about those efforts. Additionally, there is no systematic survey of the state-of-the-art of cable yarding technology, and the available information is spread out.

The paper aims (1) to present the state of technology for both, yarder technology, and cable-based harvesting systems (harvest layout, work design, material and information flow), and (2) to identify challenges for future development. It focuses on the advance of tower yarder technology in Central Europe, and neglects sledge yarder technology that has been of decreasing importance. We will first analyze yarding functions and the technical solutions to achieve them. Then, we will present the physical arrangement of cut-to-length (CTL) and full-tree (FT) harvesting systems and their operational efficiency. The paper finally identifies possible paths of future improvements.

## 2 Development of Yarder Technology

### 2.1 Implementation of yarding functions

Most publications and textbooks on forest cable systems (KONUMA and SHIBATA, 1976, LILEY, 1983, SAMSET, 1985, STUDIER and BINKLEY, 1974, TRZESNIOWSKI, 1997) provide detailed technical information of single yarders. This makes it sometimes difficult to understand the functional essence and the underlying design principles. Recently, axiomatic design tries to overcome those shortcomings by separating the generation of requirements and the selection of means for (COCHRAN, online). It first maps the functional concept in solution neutral terms. Next, the designers must develop a design solution describing a general system or structure for implementation. Following this line of reasoning, we will first develop a framework of yarding functions, and then describe technical development for the main functional groups.

Fig. 1 maps the yarding functions in a three-dimensional coordinate system. The x-axis follows the direction of the cable roads, while the z-axis describes the vertical dimension. Many descriptions of yarding systems rely on two-dimensional x-z plane representation. Because of this, many technical solutions focused on functionality in the x-z plane, especially for clear-cutting operations. Thinning and selective cutting operations have had a long tradition in Central Europe. They require a lateral movement of logs from the stump to the cable road,

<sup>1</sup> Professor of Forest Engineering, Swiss Federal Institute of Technology, Forest Engineering, ETH-Zentrum, HG G 23, CH-8092 Zurich, Switzerland, [heinimann@fowi.ethz.ch](mailto:heinimann@fowi.ethz.ch)

<sup>2</sup> University Assistant, Institute of Forest and Mountain Risk Engineering, Peter-Jordan-Strasse 70/2, A-1190 Vienna, Austria, [stampfer@mail.boku.ac.at](mailto:stampfer@mail.boku.ac.at)

<sup>3</sup> Forest Technician, Mayr-Melnhof Forest Enterprise, Mayr-Melnhofstrasse 14, A-8130 Fronleiten, Austria, [office@mm-forst.at](mailto:office@mm-forst.at)

<sup>4</sup> Professional Forest Engineer, Caminada & Partner Ltd., Chli Ebnet 1, CH-6403 Küssnacht, [caminada@cp-air.ch](mailto:caminada@cp-air.ch)

which is represented by the y-dimension of Fig. 1. The following groups of cable yarding functions can be identified:

- *Transportation functions* (x-direction): moving the empty carriage from the landing to the stand, stopping, releasing, moving the load to the landing, stopping;
- *Hoisting functions* (z-direction): lowering the hook to the ground, lifting the load, lowering the load at the landing, lifting the empty hook from the ground;
- *Skidding functions* (y-direction): pulling out the main line from the cable road to the logs, pulling in the load from the stump to the cable road;
- *Handling functions*: attaching the load to the hook, releasing the load from the hook, gripping the logs and swinging them to the deck, piling;
- *Energy transfer functions*: providing power to pull the lines, recovering, and storing energy.

In Europe, *transportation functions* rely on skylines as the main component of the cable structure. Loads are moved on the skylines by main lines that have in some cases to be combined with haulback lines for valley mounted yarders and downhill extraction. Originally, mechanical gears transmitted power from an engine to the winches what required shifting and breaking operations. Kurt Vyplel, the most important pioneer of European mobile tower yarder technology, developed a new mobile tower yarder in 1972 with all winches powered hydraulically (LOSCHKE, 2001, VYPLEL, 1992). Advantages of this solution were: (1) infinitively variable gear, (2) high horsepower - low weight ratio of hydraulic components, (3) simplification of the man - machine interface design due to multi - function control. The use of fluid power was the starting point to a new generation of Austrian mobile cable yarders. Hinteregger who built his first mobile tower yarder in 1966 developed several types of URUS yarders (1976 to 1980). KOLLER started in 1975 with the K-800, a big yarder that was followed by one of the most successful machines, the K-300 in 1977. STEYR introduced the biggest European yarder, the KSK-16, in 1977, and other manufacturers followed later, such as BACO in 1982 with its MS-500 (TRZESNIEWSKI, 1997). Again, Vyplel improved the carriage movement by automation. In 1983 he introduced the MAYR-MELNHOF HYDRO CRANE 80 (LOSCHKE, 2001). This yarder had an automatic control device for carriage movement and stop. The operator has to preset the locations of intermediate

supports and to determine the exact take up position at the felling site for each load cycle. The control device moves the carriage out at maximum speed, slows it down for passing intermediate supports, accelerates it again to maximum speed, and stops it at the desired location of the felling site. The choker setter then takes over control, attaches the load, and transfers the control again to the system. The automatic control device moves the load along the skyline, slows its down for passing intermediate supports, moves it to the landing where it stops the carriage. The yarder operator lowers and releases the load before the next yarding cycle starts. Automatic control of moving and stopping the carriage has reached maturity, and is now offered by the all manufacturers of mobile tower yarders (see table 2).

*Hoisting and skidding functions* enable taking up a load from the ground. For fixed skyline configurations, as they are common in Central Europe, the hook has to be lowered by a skidding line. There are *several slack pulling mechanisms* used to achieve lowering and lifting of the skidding line. European slack pulling mechanisms have its origin in an invention of Jakob WYSSSEN, Switzerland, in 1939. He used the main line for both, the moving and the skidding function. A stopping catch that could be moved to any point of the skyline was used to hold the carriage in a fixed position and to release the main line with the hook from the carriage at the same time. After pulling in the load, the hook catches to the carriage and releases at the same time the carriage from the stopping catch. The use of a skyline clamp that could be triggered remotely was the next step of improvement. BÜTTIKOFER (Switzerland) invented a hydraulic - mechanic clamping mechanism in 1948 that was the beginning of the automatic BACO carriages in Switzerland. Stopping the carriage and reversing the travel direction for a short distance triggers the mechanism (*reverse movement triggered*). BACO redesigned this carriage in 1956, bringing it to the market as the BK-20 type. Approximately at the same time, in 1955, WYSSSEN (Switzerland) developed a carriage that triggered the clamping mechanism by stopping the carriage and holding it for a specific time interval (*time triggered*). In 1964 KOLLER (Austria) developed the first automatic Austrian carriage, the KOLLER SKA 2.5 (TRZESNIEWSKI, 1997). In 1989, MAYR-MELNHOF launched the SHERPA carriage. It had two clamps, a main line clamp, and a skyline clamp. Both clamps could be operated simultaneously by radio control, clamping the first clamp while releasing the second clamp, and vice versa. Other manufacturers introduced radio controlled clamping mechanisms by the beginning of the 1990s.

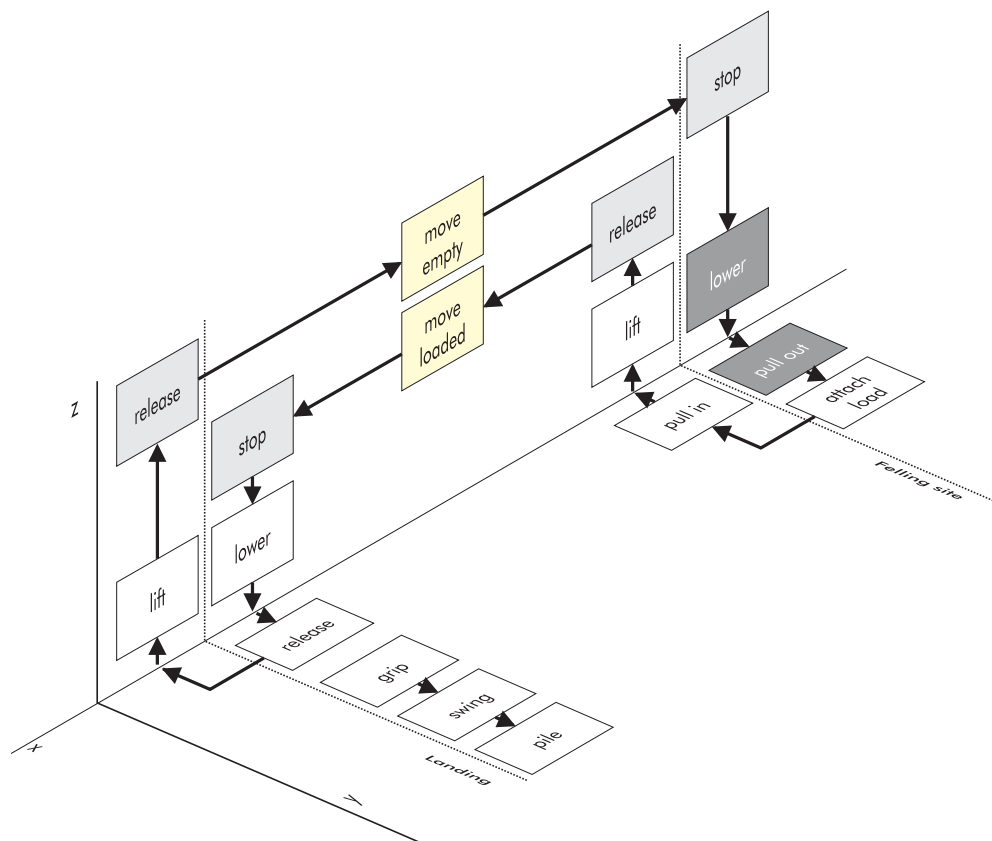

Fig 1: *Technical functions of a cable yarding system.* There are four functional groups: (1) transportation (x-axis), hoisting (z-axis), skidding (y-axis), and handling (y-axis).

**Passive slack pulling mechanisms** are only working if the yarder is mounted uphill the cable road, and if the cord slope of cable segments is bigger than about 15%. Down-hill and flat-terrain yarding require a mechanism that pulls the skidding line actively slack. This requirement came into discussion with the introduction of mobile tower yarders in Central Europe in 1963. In 1964, Vypel of MAYR-MELNHOF used a drum that was mounted together with a sheave on a shaft in the carriage (VYPLEL, 1992). Unwinding the auxiliary line (slack pulling line) from the drum pulls slack the main line by using the sheave as the capstan. Active slack pulling mechanisms have positive effects on the choker setter's workload, and on the efficiency of the lateral yarding process. This slack pulling principle is still widely used (table 1).

There has been a recent trend to improve **active slack pulling mechanisms** (Table 1), aiming to provide power supply integrated into the carriage. MAYR-MELNHOF and KOLLER developed carriages that used combustion engines as a power source (1998). GANTNER launched a slack pulling carriage (2001) that uses an electric motor to

drive the sheave while the battery is charged by a small alternator coupled to one of the skyline sheaves. STUEFER uses a hydraulic accumulator as a power source for a fluid motor. One of the skyline sheaves is coupled with a hydraulic pump that charges the accumulator while moving along the skyline. The electric driven slack puller has a big potential for future development because of its low self-weight.

Tab. 1: Active slackpulling carriages of the most important Central European Manufacturers.

Power source for pulling slack	Manufacturer	Carriage type
Line, operated by the yarder	GANTNER	BK-25
	KOLLER	USKA 2.5 Z
	MAYR-MELNHOF	SHERPA-U
	STUEFER	HUSK 2000
	TRÖSTL	T 2500/I
	WYSSSEN	HY-3A
Combustion engine integrated into carriage	KOLLER	MSK-3
	MAYR-MELNHOF	SHERPA-MOT
Battery powered electric motor integrated into carriage	GANTNER	BK-25 E slack-puller
Hydraulic accumulator powering a fluid motor integrated into carriages	STUEFER	HASK 3500 Under development

Energy efficiency of a yarder depends on how the so-called **“interlock problem”** is solved. The interlock-problem is the need to recover energy potentially wasted at one drum (e.g., in the haulback drum during inhaul) and to make it available as a power supply to other drums (main line) (CARSON and JORGENSEN, 1974) Fluid power transmission simplified the achievement of interlock by using direct drive interlocks. A new interlock device, the TRÖSTL INTERLOCK, was patented, and implemented into the SYNCROFALKE yarder in 1994. The main characteristic of the TRÖSTL INTERLOCK mechanism is the coaxial arrangement of the following components: (1) main fluid motor, (2) main line drum, (3) interlock fluid motor, and (4) haulback line drum. The fluid motor is driving a shaft on which the main line drum is fixed. The main line drum is connected to a second fluid motor, the interlock motor. The shaft of the interlock motor is connected to the haulback line drum. Main line and haulback line are wound in opposite directions. Turning the mainline drum and the haulback line drum into the same direction winds up to the main line while unwinding the haulback line, and vice versa. The two drums are of large diameter (1 m), resulting in similar speed of the two lines. The interlock motor has to balance only the force difference between the main line and haulback line, caused by different winding diameters. This specific coaxial arrangement results in a simple fluid power control scheme and a compact type of construction.

## 2.2 Integration of system components

Integration is an important principle of technical progress. The first important step of yarder technology integration was the development of mobile tower yarders. Their characteristic is the integration of drums, power supply, and a steel spar on a wheeled or tracked carrier. In Central Europe, Kurt Vyplel from MAYR-MELNHOF initiated this important step in 1963 with the development of the so-called "GÖSSER TOWER YARDER" (TRZESNIEWSKI, 1997). The Austrian state forests initiated a second important step of integration in 1979. They integrated handling and processing functions into cable yarders by developing the so-called "MAUKO PROCESSOR TOWER YARDER". They added a boom to a truck - mounted tower yarder (figure 2) to which either a grapple or a processor could be attached. Gripping capabilities of the processing head are absolutely crucial. Therefore, KONRAD (Austria) developed a special processor head with the capability of lifting up the feeder rolls (WOODY processor).

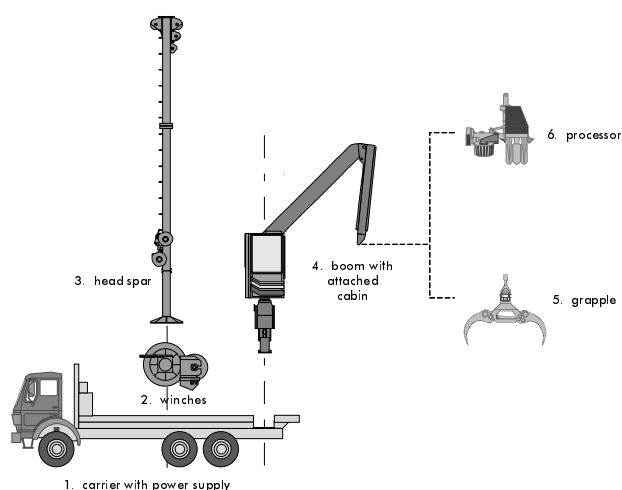

Fig 2: System components of yarders: (1) carrier with power supply, (2) winches, (3) steel spar, (4) boom with attached cabin, (5) grapple, or (6) processor.

In 1994, Mayr Mehlhof was first to attach the operator cabin to the boom, providing optimal visibility and working conditions for the operator. Another characteristic of the Syncrofalke is the turntable on which the steel spar and the winches are mounted. A swinging range of about 240 degrees makes it possible to access optimal cable roads even under unfavorable setup conditions of the yarder. KONRAD (Austria) went one step further by assembling the steel spar, the boom and the operator cabin on one turntable what represents the present state of integration. By the end of the 1990s processor tower yarders PTY equipped with radio controlled carriages and automatic carriage movement and stop have become standard for all manufacturers (table 2).

Tab. 2: Processor Tower Yarders PTY of Central European Manufacturers.

<b>Manufacturer</b>	<b>Yarder Type</b>	<b>Possible Processor Types</b>
HERZOG	GRIZZLY-1000	
KOLLER	K-500	KETO 150
KONRAD	MOUNTY-4000	KONRAD WOODY 50 KONRAD WOODY 60
MAYR-MELNHOF	SYNCRO FALKE	SILVATEC 445 MD50 SILVATEC 555 MD60
TRÖSTL	TST 700	WOLF 50 B
VALENTINI	V 600	
WOLF	PKM 12	

### 3 Production Systems Development

#### 3.1 System representation principles

Operational efficiency depends far more upon rational organization of work processes than upon capabilities of machines or individual skills. A precondition to improve manufacturing productivity is the need for a technique to analyse and represent the functional requirements rather than physical or organizational implementations. Cable yarding production systems will be represented by "box and arrow" graphics that show functions as boxes and interfaces to or from functions as arrows entering or leaving the boxes (figures 3 and 4). This approach supports the aim of integrating machine design and cell design, or manufacturing systems design, respectively (COCHRAN, online). We will present two state-of-the-art cable-based production systems, a cut-to-length CTL system, and a full-tree FT system

#### 3.2 Cut-to-length CTL-system

"Cut-to-length CTL" means that the conversion of trees to logs is done at the stump site before the extraction operation (figure 3). Felling, limbing, and bucking are all done at the stump site. Motor-manual systems use workers equipped with chainsaws. Mechanized systems are based

on steep slope harvesters with the capacity to level the swing table. Several logs are choked to a single load, which is attached to the mainline and extracted partially or fully suspended by a cable yarder to the landing. Harvest system geometry has to suit the width of a harvester swath with the width of one cable corridor (HEINIMANN, 1999). A cable corridor width of 30m has to match either one or two harvester swath widths what results in boom reaches of 15m and 7.5m, respectively. As a consequence, a steep slope harvester with a boom reach of 15m was developed, the IMPEX BENGAL TIGER. Interface design between the subsystems "conversion" and "extraction" is essential (HEINIMANN et al., 1998). The bunch size has to fit to the load carrying capacity of the cable yarder, what increases productivity. Since handling functions have been integrated into the yarder, a minimal crew size of only two is needed, one choker setter and one yarder operator. The automation of the carriage movement and stop between the landing and the load pick up location provides time for the operator to grip, swing and pile the released logs. CTL systems are feasible for both, uphill and downhill yarding. However, they are superior for downhill operations because of less damages to residual trees than full-tree FT-systems (STAMPFER, 2000).

#### 3.3 Full-tree FT-system

"Full Tree" means that the conversion of trees to logs is done after the extraction operation at the landing or at mill site (figure 4). Only felling is done at the stump site. For selective cutting operations, only motor-manual felling has been used in Central Europe. Several trees are choked to a single load, which is attached to the mainline and extracted by a cable yarder to the landing. After releasing the load, a boom-mounted processor head limbs and bucks the trees, and piles the logs. Figure 4 maps a system in which the subsystems "felling" and "yarding-processing" are detached. However, it is possible to integrate the two subsystems in thinning operations. In this case, the choker setter has to do both, felling, and setting chokers. The FT-system mapped in figure 4 requires automatic carriage movement and stop between the landing, the load pickup location, and vice versa. As for the CTL-system, the yarder operator gains time to process the trees to logs, and to pile. FT-systems are best suited for uphill yarding operations. Although downhill yarding operations are technically feasible, they cause high damages to the residual stand (up to 40%) (STAMPFER, 2000).

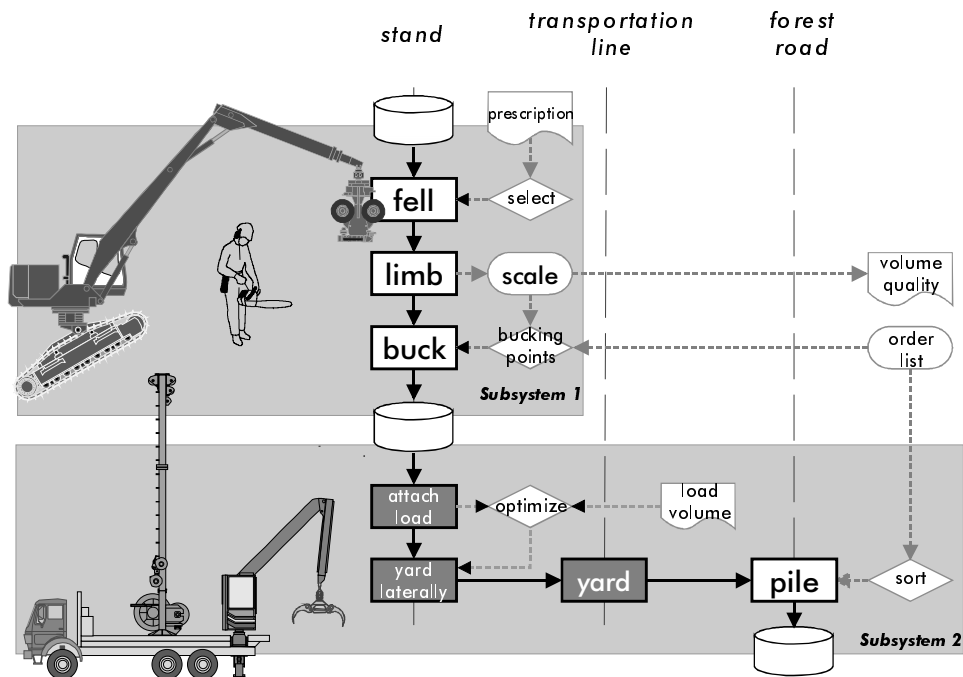

Fig 3: Cut-to-length CTL cable yarder production system. Felling and processing is either done motor-manually, or by a steep slope tracked harvester. Handling functions (gripping, swinging, piling) are integrated into the yarder.

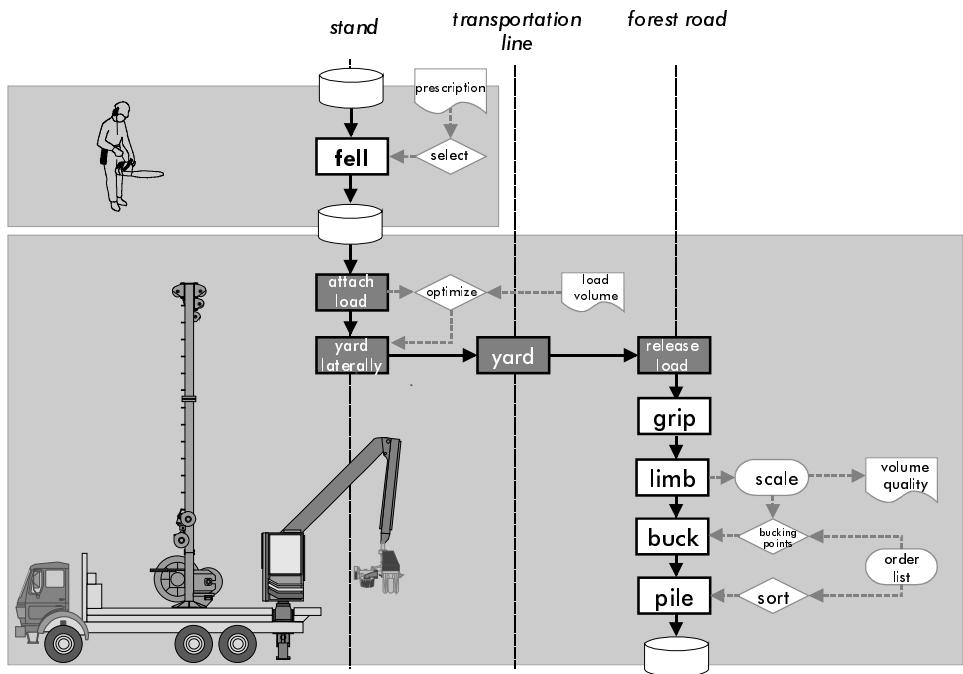

Fig 4: Tree-length TL cable yarder production system. Processing is done at the landing with a boom-mounted processor that is integrated into the yarder.

### 3.4 Performance optimization

System productivity is, besides system cost, the main factor influencing operational efficiency. Productivity of a specific cable yarding system depends on the following factors: stem volume, yarding distance, lateral yarding distance, yarder type, bunching strategy, and learning curve effect of the crew. There are several available productivity models for cable yarder systems. However, they are empirical and are limited to the conditions, which were present during the underlying experimental study. Unfortunately, there are no studies available on the influence of technological progress on productivity. The effect of the automation of carriage movement and stops is estimated in the order of 10 to 15% increasing system productivity (VYPLEL, 1992).

Fig. 5 shows productivity models that represents a state-of-the-art cable yarder operated by top-level crews in Austria. Tree volume is the main factor of influence. Furthermore, the choice of system (CTL vs. FT), and the bunching strategy affect system productivity considerably. For selective cutting operations, the fully mechanized CTL-system (cable yarder after steep slope harvester) provides yarder productivities that are 40-100% higher than for the motor-manual CTL-system (cable yarder after motor-manual felling and processing). In thinning operations, full-tree FT extraction provides productivities that are 0-10% lower than for the motor-manual CTL-system. Turning in full trees from the stand into the cable road is time demanding, resulting in slightly lower productivities. Yarding distance has a much smaller influence than tree volume and system choice.

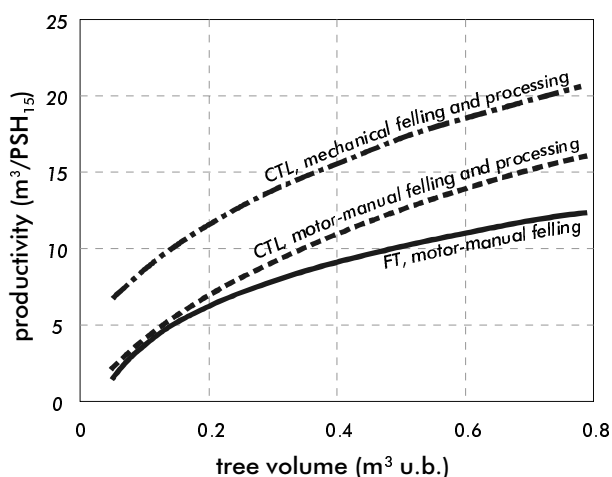

Fig 5: Productivity figures for a state-of-the-art CTL- and FT- cable production systems. Assumptions: thinning operation (35% of trees removed), mean yarding distance of 150 m, cable corridor width of 30m. Adapted from (STAMPFER, 2000, 2001)

Efficiency of different harvesting systems is expressed in

cost per cubic meter wood under bark (figure 6). Mean tree volume and the choice of harvesting systems are the main factors of influence. At present, cable yarding following motor-manual felling and processing is still widely used (motor-manual CTL system). Mechanizing tree-processing results in cost savings of about 40% for both, the CTL-system with a steep slope harvester, and the TL-system with a processor tower yarder. Efficiency differences between the two mechanized systems are neglectable, although the FT-system seems to be advantageous for tree volumes over  $0.3 \text{ m}^3$ . Damages to the residual trees are different for the two systems; especially for downhill operations where up to 40% of the residual trees are damaged by using the full-tree system (STAMPFER, 2000).

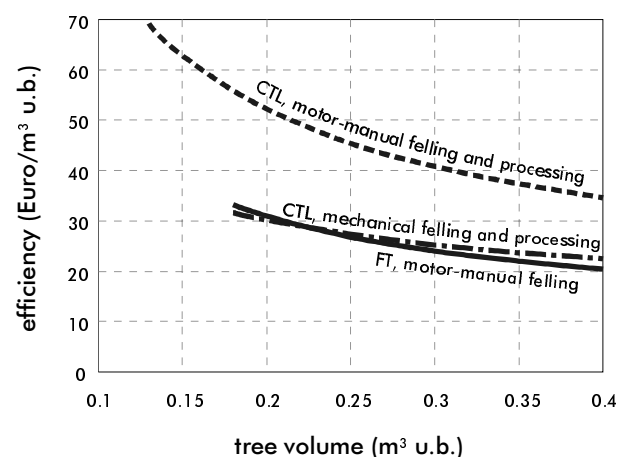

Fig 6: Cost comparison of CTL and FT-cable production systems. Figures are based on the following cost assumptions: Bengal Tiger steep slope harvester 130 €/PSH<sub>15</sub>, Syncrofalke yarder with boom and processor 145€/PSH<sub>15</sub>, worker with power-saw 25€/PPH<sub>15</sub>. Adapted from (STAMPFER, 2000)

## 4 Future challenges

We identify three paths of future improvements: (1) improving yarder and carriage concepts, (2) improving harvest systems, and (3) development of forest workers.

*Improving yarder and carriage concepts* must consider functional requirements as they were presented in figure 1. Although there are tried and tested solutions for implementing transportation, hoisting, and skidding functions, there is still a need for improvement in the following areas: (1) increase the load carrying capability of carriages and yarders to about 50 kN, (2) improve reliability of system components, especially slackpulling mechanisms, (3) continue to provide some intelligent behavior of yarders and carriages (mechatronics, automation). There is still a lack of satisfactory solutions for handling functions. Self-releasing chokers have become available. Reducing their self-weight while improving reliability will remain a challenge for the next years. Since we know that bunching affects yarder productivity positively, we should

strengthen future development on “unitized” loads, i.e. handling several logs as one unit. Conveying logs and unitizing them to standard loads by a harvester could be a possible path of development (HEINIMANN, 1999). Integration of processing functions into a carriage is a long-standing idea that is difficult to implement. Another problem is the economy of scale of the yarder manufacturing industry that has its tradition in craftsmanship, which is no longer appropriate to meet the technically demanding challenges. Hopefully, Central European cable yarder manufacturers will merge to a few competitive companies that will deal with international markets.

*Optimization of harvest system design* is remaining an effective way of improving operational efficiency. It is essential to connect machine design with work design and geometrical system layout. The elimination of non-value-adding sources of cost is the most important goal of future improvement. This requires an increased focus on indirect times, such as production disruptions, and setup processes. The optimization of interfaces (buffers) within the production process offers potential for improvement. Bucking to value, and bucking to order are concepts to improve value for the customer. The Nordic harvester-forwarder technology involves decision-support systems to optimize bucking, and to allocate lots to customers. Those take account of a data standard (SKOGFORSK, 1997) supported by most of the Nordic harvester head manufacturers. STANFORD (Standard for Forest Data and Communication) provides file structures for (1) bucking prescription, (2) production (3) operations-follow up, etc., that need to be introduced into cable harvesting systems.

A change of harvest systems and technology are causing *new skill demands for operators and forest workers*. Worker selection and training has to be adapted. MAYRMELNHOF developed a simulator (Syncrotronic) that provides an environment to train the operation functions of a the SYNCROFALKE yarder (LOSCHKE, 2001). The simulator avoids the high operating cost of a real yarder and prevents machine damage caused by incorrect operation. An Austrian forestry training center, Pichl in Styria, owns a downscaled model (1:5) of the SYNCROFALKE with all the system controls of the real machine. It is well suited to get familiar with automatic carriage movement and stop, and to understand system functionality before starting on-the-job training in the forests. Virtual reality could be a possible future training environment that could simulate the behavior of different yarder systems and different stand conditions.

## 5 Conclusions

The paper aimed to present the state of technology for both, cable yarders, and harvesting system layout. Analysis of technological advance resulted in the following findings: (1) the introduction of fluid power in the 1970s initiated a rapid development of compact tower yarders; (2) the degree of functional integration increased (winches, steel spar, power supply, boom, and processor head on one carrier), and (3) automation and remote control of carriage functions have reached maturity. Harvest system design was a second path of improvement. It resulted in mechanized thinning operations on slopes (CTL- and FT- systems) that saved about 40% of the cost compared to motor-manual felling and processing. The CTL-system is superior for downhill yarding operations because damages of residual trees are lower. Future improvements will focus on improving the reliability of system components, on unitizing loads, on introducing bucking-to-value and bucking-to-order technology, and on improving operator training with simulators.

Previous studies on the state of cable yarding technology (KONUMA and SHIBATA, 1976, LILEY, 1983, SAMSET, 1985, STUDIER and BINKLEY, 1974) focused on the description of single systems. The present approach attempts to separate the functional essence of both, yarders and harvesting systems, from mechanisms and structures for implementation. Graphical representation of yarder functions (figure 1) and system mapping (figures 3 and 4) are techniques to analyze and communicate harvesting system concepts. Future work should concentrate on the integration of yarder design and harvest system design, following the paradigm of axiomatic design (COCHRAN, online). Efficiency improvement will remain important, but has to consider ecological indicators (eco-efficiency), too.

## REFERENCES

- CARSON, W.W. and J.E. JORGENSEN. 1974. *Understanding interlock yarders*. USDA Forest Service, Pacific Northwest Forest Range and Experiment Station. Portland, Oregon, USA. Research Note, PNW-221. 13 p.
- COCHRAN, D.S. online. *Production System Design Laboratory [accessed Nov-15 2001]*. Laboratory for Manufacturing and Productivity, Massachusetts Institute of Technology MIT. Available from Internet: [http://psd.mit.edu/MSDDFrameset.htm].
- HEINIMANN, H.R. 1999. *Ground-based harvesting technologies for steep slopes*. In Proc., *International Mountain Logging and 10th Pacific Northwest Skyline Symposium*, eds. J. Sessions and W. Chung, 1-19. Corvallis OR, March 28- April 1, 1999. Department of Forest Engineering. Oregon State University. Corvallis, OR 97331.
- HEINIMANN, H.R., R. VISSER, and K. STAMPFER. 1998. *Harvester-cable yarder system evaluation on slopes - a Central European study in thinning operations*. In Proc., *1998 COFE conference on "harvesting logistics - from woods to markets"*, eds. P. Schiess and F. Krogstad, 39-44. Portland, OR, USA, July 20-23, 1998. Council on Forest Engineering COFE.
- KONUMA, J.-I. and J.-I. SHIBATA. 1976. *Cable logging systems in Japan*. Bull. For. Exp. Sta. (283): 117-174.
- LILEY, W.B. 1983. *Cable logging handbook*. New Zealand Logging Industry Research Association. Rotorua, New Zealand. 103 p.
- LOSCHKE, J. 2001. *Development of mechanized logging*. In Proc., *Joint FAO/ECE/ILO Workshop on New Trends in Wood Harvesting with Cable Systems for Sustainable Forest Management* Ossiach, Austria.
- SAMSET, I. 1985. *Winch and cable systems*, Ed. Dordrecht: Martinus Nijhoff / Dr. W. Junk Publishers. 539 p.
- SKOGFORSK. 1997. *Standard for forest data and communication StanForD*. Skogforsk, the Forest Research Institute of Sweden. Uppsala, Sweden. unpublished. 9+46 p.
- STAMPFER, K. 2000. *Efficiency of mechanized steep terrain harvesting systems*. In Proc., *23rd Annual Meeting of the Council on Forest Engineering and the 81st Annual Meeting of the Canadian Woodlands Forum "Technologies for New Millennium Forestry"*, ed. D. Guimier, 4. Kelowna, BC, Canada, September 11-13, 2000. FERIC, Pointe-Claire, QC.
- STAMPFER, K. 2001. *Multi-criteria evaluation of thinning operations in steep terrain*. In Proc., *Joint FAO/ECE/ILO Workshop on New Trends in Wood Harvesting with Cable Systems for Sustainable Forest Management* Ossiach, Austria.
- STUDIER, D.D. and V.W. BINKLEY. 1974. *Cable logging systems*. Division of Timber Management, Forest Service, US Department of Agriculture. Portland, Oregon. 205 P.
- TRZESNIEWSKI, A. 1997. *Forstmaschinen und Holzbringung II [Forest machines and timber extraction II]*. Institut für Forsttechnik, Universität für Bodenkultur. Wien. Vorlesungsunterlagen [Lecture Notes]. 188 p.
- VYPLEL, K. 1992. *Entwicklung und Stand der mobilen Seilbringung in Österreich [development and state of mobile cable yarding in Austria]*. In Proc., *26. Internationales Symposium zur Mechanisierung der Waldarbeit*, ed. A. Trzesniowski, 31-47. Wien. Institut für Forsttechnik, Universität für Bodenkultur Wien.